

FEDERATION CYNOLOGIQUE INTERNATIONALE (AISBL)

Place Albert 1er, 13, B – 6530 Thuin, Belgique, tel : +32.71.59.38.23 internet : <http://www.fci.be>

INTERNATIONAL RULES OF MONDIORING COMPETITION



If any discrepancy appears, the regulations in French will serve as reference.

TABLE OF CONTENTS

I – FOREWORD.....	5
II – DECOY.....	6
III – REGULATIONS.....	7
1 – Presentation.....	7
2 – Instructions common to all exercises.....	7
3 – Recall commands at the end of exercise.....	8
4 – General Instructions.....	9
General Attitude.....	9
Conditions for participation in Mondioring competition.....	9
Organization of competition.....	10
Jury for competition.....	10
Competition field.....	10
Competition logistics.....	11
Drawing lots.....	11
Dog in White.....	11
Food.....	11
Baton.....	12
<i>Decoy Suit</i>	12
Commands.....	12
Score sheets.....	12
Functions and duties of Judges.....	12
IV – OBEDIENCE EXERCISES.....	13
1. Heeling without Leash.....	13
Account of the exercise.....	13
Penalties.....	13
2. Absence of Handler.....	13
Account of the exercise.....	13
Penalties.....	14
3. Send Away.....	14
Points awarded.....	14
Description of the exercise.....	14
Account of the exercise.....	14
Penalties.....	15
4. Positions.....	15
Points awarded.....	15
Description of the exercise.....	15
Account of the exercise.....	16
Penalties.....	17

5. Refusal of Food.....	17
Description of the exercise	17
Account of the exercise	17
Penalties	18
6. Retrieve of a Thrown Object.....	18
Description of the exercise	18
Account of the exercise	18
Penalties	19
7. Search for an Object.....	19
Description of the exercise	19
Account of the exercise	20
Penalties	21
V – JUMPING EXERCISES.....	22
1. Palisade	23
Regulation heights and points	23
Description of the exercise	23
2. Long Jump	23
Regulation lengths and points	23
Description of the exercise	24
3. Hurdle.....	24
Regulation heights and points	24
Description of the exercise	24
Account of the exercise	24
Penalties (common to all 3 jumps)	25
Penalties (hurdle only).....	25
VI – BITING EXERCISES.....	26
1. Face Attack with Baton	26
Breakdown of points.....	26
Description of the exercise	26
Account of the exercise	27
Penalties	28
2. Face Attack with Accessories	28
Description of the exercise	28
Account of the exercise	29
Penalties	29
3. Flee Attack.....	30
Breakdown of points.....	30
Description of the exercise	30
Account of the exercise	30

Penalties	30
4. Stopped Flee Attack	31
Breakdown of points.....	31
Description of the exercise	31
Account of the exercise	31
Penalties	31
5. Search and Escort.....	32
Breakdown of points.....	32
Description of the exercise	32
Account of the exercise	33
Penalties relating to Search and Escort	35
6. Defence of the Handler	35
Description of the exercise	35
Account of the exercise	36
Penalties	37
7. Guarding an Object	37
Description of the exercise	37
Account of the exercise	38
Penalties	39
VII – TABLE OF POINTS	40
VIII – THE JUMPS – TECHNICAL PLAN	42
1. Hurdle.....	42
2. Palissade.....	43
3. Long jump.....	44
IX – ABBREVIATIONS.....	45
X – FINAL PROVISIONS.....	45

I – FOREWORD

Mondioring was created by delegates from several countries in Europe and America, in hopes of utilizing different portions of already existing national dog sports and allowing an enriching union of all the enthusiasts of working dogs, beginners or experienced. Its goal is to be entertaining for the spectators, a game of progressive difficulties for the participants, and a competitive sport for the training enthusiasts.

To practice Mondioring, you will need a fenced field equipped with various materials, and one or two decoys, protected by a bite suit, who will be the partners of the dog, of the dog handler; and of the judge to determine the best dog and handler team of the day, under the conditions provided for by the regulations. These regulations concern trial procedures, the points allotted to the exercises, and the penalties related to faults committed.

To be accessible to the largest group of enthusiasts, Mondioring must be concise in its description, simple in its practice, and clear in its judgment. The judges must never forget the intent, which motivated the originators of this program, each time there is a discrepancy in the regulations. They must, above all, respect the spirit of these regulations and prohibit any abusive interpretation prejudicial to the dog.

The purpose of Mondioring is to highlight the aptitudes of the dog, the quality of its training, the control of its handler, and especially, the genetic inheritance of the dog.

The program consists of three disciplines, which will proceed in the following order:

1. Obedience exercises
2. Jumping exercises
3. Biting exercises.

The order of the exercises will be the same for everyone.

Note: The Mondioring regulations have been translated into several languages and differences may appear between the translations. If any discrepancy appears, the regulations in French will serve as reference.

II – DECOY

For a brief history, let us mention that in the past the decoy has also been called “*Apache*”, “*Malfaiteur*” (lawbreaker), “*Mannequin*”, and “*Paillasse*” (strawman). In America we call him “Decoy” (lure) or “Helper” (assistant). Each one of these terms carries with it a philosophy of the art of training and it will be interesting to be able to add to this list the terms used in Germany, Spain, Holland, Italy or Switzerland, if they are different. For it is the name of the decoy (lit. trans. assistant man), which for simplicity we use the initials H. A., Compared with the “*hunting dog*”, “*defense dog*”, “*guard dog*”, the man is not truly “*attacking*”, because generally he defends himself, flees, or steals an object entrusted to the dog.

What he is, as said in the preceding section, is the partner of the dogs and the handlers. He must also be an adversary, because he must collaborate with the Judge in the competitions, to help the Judge to classify the dogs by order of merit.

If the Decoy merely maintains a passive behavior, he is only a moveable puppet, good only to be bitten. If his role is to allow the Judge to evaluate the quality of the dog, he must oppose the animal. As he is protected by his bite suit, he risks exaggerating this opposition. He risks also, knowingly or not, behaving differently from one dog and another.

His is a difficult position, but he will have to always hold it in the best sporting spirit.

Without analyzing the work of the Decoy technically, we should lay down three golden rules never to be forgotten:

1. The Decoy will be absolutely impartial.
2. He will never inflict, in any manner, physical pain upon the dog.
3. He will have to behave as if he were not wearing a protective bite suit, and therefore, use promptness, deception, threats, and dodging to defend himself or impress the dog.

The Decoy will in no case strike the dog with the baton.

When he uses the revolver, he will fire in the air, at an angle of about 45°.

At the beginning of ***the Face Attacks***, the Decoy will always place himself at a distance of 10 to 20 meters away from the ***start of the exercise*** in the central line of the attack.

At the beginning of the Flee Attacks, the Decoy will always place himself at a distance of 10 meters away from the start of the exercise in the central line of the attack. It is forbidden for the Decoy to speak and order the dog by voice (physical gestures are allowed).

If liquid is to be used, only water is acceptable.

The Judge is responsible for the work of his Decoy, and the Decoy must conform to his regulations.

For levels 2 & 3, two decoys will share the exercises at the judge’s choice. Level 1 can be done with just one decoy.

The selection of the Decoy is carried out in each participating country by methods that are determined by that country.

III – REGULATIONS

1 – Presentation

All handlers must be present for Dog in White and will be dressed appropriately. All use of rewards (food or toy) is forbidden and will result in the exclusion from the competition.

The handler enters the field with his dog, at the invitation of the Deputy Judge of the ring. He will then follow the Deputy Judge to the Judge's table to present himself to the Judge, his dog at heel, without leash, collar, or muzzle. He will indicate the initial length and heights chosen for the jumps. He will also specify to the Judge if he is calling his dog from distance by voice or with the whistle.

In Level III, the handler will then choose an envelope in which is stated the nature of the first Flee Attack. Without opening it, he will give it at once to the Judge who will be the only one to know, until after the departure of the dog to the attack, if it is a Flee Attack or Stopped Attack [see process in the description of the attacks]. ***The Judge must indicate on the scoresheet, before routine begins, if the Stop Attack is the 1st or 2nd, unless there are two judges officiating: in this case the two judges know the order.***

In Level II & III the handler will choose the piece of numbered wood intended for the Search for an Object ***with his/her back to the dog and without showing the wood to the dog. The handler may hold the wood in his/her hands for a maximum of 5 seconds without any other manipulation or exposure to additional scent.*** He/she will slip it into an empty pocket. ***It is forbidden to put his/her hand in his/her pocket until the wood is placed in the designated spot with the handler's back to the dog.***

2 – Instructions common to all exercises

The handler places himself at the disposal of the Deputy Judge who leads him to the starting point of each exercise, within approximately 3 meters before the line of departure. Preparation of the dog for the exercise is allowed just before the preparation line at three meters before the Line of Departure.

It must be discrete **and quick** and **cannot** be made after the sound of the horn announcing **the authorization to take place at the line of departure**. A first sound of the horn by the Judge signals **to go to the line of departure**. **Non-compliance with the first horn signalling the move to the line of departure will result in a 2 point GA deduction**. The handler will then have 30 seconds, timed by the Judge, to position his dog and approach the Line of Departure. If the handler is not fully prepared within these 30 seconds, the exercise is cancelled. The handler may give only one position command (sit, down, stand, according to the exercise). He may then give an optional stay command, example: not to move, place, stay. Any repetition of any of these commands (position or stay) is regarded as an additional command and is penalized one point. If the handler has to give 5 additional commands, the exercise is cancelled, even if the 30 seconds granted for the preparation has not passed.

As soon as the handler and his dog are in their respective places at the Line of Departure, the Judge will give another sound of the horn which indicates the start of the exercise and the handler will use the appropriate starting command, which may be preceded by the name of the dog. Any irregular command will involve a penalty.

3 – Recall commands at the end of exercise

There are two types of recall commands, the distance recall and the close recall (1 meter or closer). The close recall is regarded as a recall to heel.

All the distance recalls can be made by voice or with the whistle. The handler must inform the Judge at the time of the presentation the type of distance recall chosen and keep to it under pain of penalization. All the close recalls must be made by voice.

Whether made by voice or with the whistle, the recalls must be short and be given without hesitation. A non-continuous recall command is regarded as an additional command and penalized as such.

Only one command for recall is allowed. Any additional recall is penalized [*see exercise by exercise*]. In the case of a disobedient dog, which would require additional recalls, his handler would lose extra points on General Attitude.

Similarly, if the dog continues to bite beyond 5 seconds of the end of the biting exercise, whether recalled or not, loses the 10 points to the return without counting eventually the General Attitude points at the discretion of the Judge.

The dog, which does not return to heel during the allotted time, loses the 10 points attributed at the end of the biting exercises. In Level I, the handler may allow his dog to guard the Decoy, instead of a recall, at the end of the **Attack** exercises. He must inform the Judge of this at the time of presentation. **If, after 30 seconds from the first recall command, a dog does not stop biting in all the attacks, the judge will request the handler to leash the dog and leave the field. If the handler moves without authorization in order that the dog stops biting after the first command in any biting exercise, the judge will request the handler to leash the dog and leave the field. In both cases the dog will be disqualified and will lose all points accumulated. "Disqualification" will be marked in the scorebook.**

4 – General Instructions

General Attitude

If the Judge believes the execution of an exercise leaves something to be desired, he will apply a penalty of up to 10% of the points obtainable in the exercise in question. This applies as well to any inappropriate behaviour of a competitor before, during, or after its round. The severity of the penalty will be at the Judge's discretion.

All intervention of a competitor in front of the Jury during the round, other than informing them of illness of himself or his dog, is strictly forbidden. This is punishable by a penalty of 10 points in General Attitude and expulsion from competition if the violation is repeated.

The penalties toward General Attitude are applied as a deduction from the total points gained by the competitor.

In case of a serious incident, the Judge can expel the competitor and confiscate his score book. He will also furnish a detailed fact-finding report that he would forward to the National **committee**, also to the Chairman of the concerned regional Canine society.

Conditions for participation in Mondioring competition

The handler must have a score book issued by the responsible Mondioring authority of his country. Any breed of dog is admitted. The dog must hold a pedigree issued by a canine society recognized by the International Cynological Federation (F.C.I.). To begin Mondioring competition, a dog must also be at least 12 months old. **All dogs must have completed a recognized sociability test and a health record.**

Before being able to compete in Level III, a dog must pass the following stages:

- qualify in Level I by twice obtaining at least 160 points out of 200, and
- qualify in Level II by twice obtaining at least 240 points out of 300.

If the handler wishes, he may remain in his level as long as he desires. Also, a handler is allowed to compete in Level II as often as he deems it useful as long as the competing dog has not achieved 300 points **at level III.**

A dog competing in Ring may begin in Mondioring in the level in which he competes in Ring in his home country. A dog that participates in national trials (selective/regional competitions for the national championship) in his country with the highest category must directly start in Level III of Mondioring.

Following the rules of the FCI, male dogs which participate in Mondioring trials must have two testicles that appear normal and completely descended into the scrotum.

As soon as the competition field is laid out, access will be forbidden to all competitors under pain of exclusion from competition.

The use of electric collars, prong collars, corrective collars etc. within on the competition field, parking lot, etc. is subject to disqualification.

Organization of competition

Organizations who wish to organize competition must take the greatest care in their preparation and neglect no detail. They should inform, by all possible means, the coordinating organizations of each country, in order to benefit from foreign participation.

Jury for competition

The Jury will consist of one or more qualified Judges, aided in their functions by Selected Decoys. Maximum judging time for a single Judge is 9 hours per day.

The organization must also choose a Deputy Judge, who must be current on the **programme** and rules of the trial.

One or two competent secretaries are indispensable for the competition to run smoothly. A table (chart) for the Judge will be provided in such a manner for the judges to be able to reach it while continuing to watch the work executed in the ring.

The organizer should provide a minimum of 2 field helpers, for moving the various obstacles, throwing of food, setting jumps, etc.

Competition field

The dimensions of the competition field must be at least 60m by 40m and a maximum area of 5000 square meters. The ground must not be hard, that is, neither paved nor gravel. Care must be taken that there are no objects on the field that could injure the dog. The field must be **appropriately fenced all the way to the ground**. There must be at least 2 entrances to the field, one for the handlers accompanied by their dogs, and the other for the Decoys.

The field can incorporate decorations that correspond with the theme of the trial. The theme is chosen by the organizing club.

The organizer is in charge of marking the field. A starting point for each exercise must be marked. For the Guard of an Object exercise, two concentric circles must be marked out, with a radius of 2 m and 5 m. For the jumps, the squares must be clearly marked on the ground by the palisade, by the long jump, and by the hurdle standards. For the Absence of Handler and Refusal of Food, an opening in the hiding area so the handler may see his dog during the exercise must be provided.

For the Send Away exercise, a line 20 m in length will be marked parallel to the starting point and marked by 2 posts (or flags) placed at each end. At 5 m inside the flags will be 2 perpendicular lines 1 m in length, which define the optimal zone of travel. The axis of the trajectory (centre line) needs to be in the center of the field; diagonals are not allowed; and should be free of all objects that could distract the dog. The cone markers can be replaced with items of decoration that match the trial theme.

Competition logistics

The organizer will place at the disposal of the Judges:

6 accessories for attack
1 obstacle for attack (see rules)
6 hiding places for Search and Escort + 1 mobile hiding place
3 jumps (according to the plans in the rules)
6 Retrieve objects (see list in the rules)
food (see rules)
wooden objects for search (15 X 2 X 2 cm)
2 blank guns with 6mm (triple charge) or 9 mm ammunition
flags necessary for Stopped Attack
official score sheets
1 or 2 distractions for the Absence of Handler
3 or 4 objects for Guard of an Object. It is preferred that the objects fit the theme of the trial.

The Judge will choose the retrieve object and attack accessory on the morning of the competition. During the Dog in White, the Judge must be attentive to the use of the accessory (which must never resemble the object to guard). The organizer will also provide a Dog in White for each level and for each day of the competition. For the starting signals, the organizer will provide a horn. A whistle may **not** be used, being used solely by the handlers for recalls.

A resting area (room) **that can be closed** must be available for the Decoys to conceal themselves while they are not working with the dogs. This site should be located at least 5 m from the field, and such that the dogs cannot detect the presence of the Decoys. No container of water may be placed on the field or on the boundaries **that could distract the dog from their work**. During the preparation for the search exercise, a hiding place will be provided outside the field so that the handler will be able to hide himself with his dog. A container shall be made available there, so that he may let his dog drink as much as it wants.

Drawing lots

The organizing club will hold a drawing to decide the order in which the competitors compete. It is optional for there to be a drawing for the order of the exercises. A drawing for the order of exercises is optional and at the discretion of the judge (whether or not the participants are present). Bitework will never start with the search, nor will it start with the flee in level 3.

The position for the start (sit, down, stand) of the Change of Positions **exercise** will be chosen by a drawing. Another **optional** drawing will decide the position for the Absence of the Handler.

Dog in White

It is mandatory that a Dog in White pass through each level before the beginning of a trial. Competitors must be present for the Dog in White.

Food

Food must be varied and of a reasonable size (maximum of fist-size). It will consist of raw or cooked meat, fish head, cheese, dried cake, sugar, etc. **All bones and raw pork are forbidden. (Risk of infection by the Aujeszky virus).**

Baton

The baton must be made of bamboo split in quarters, **60-80cm long with a diameter between 20 and 30 mm. The stick cannot open up like a fan during barrage.**

Decoy Suit

Must protect the decoy effectively, it must be flexible enough to allow easy movements and running in a flexible manner. The suit cannot be ridiculous in any way, cannot have too wide sleeves or be too hard for the dog to grip. The suit must allow the dog a grip of at least 7cm in depth, and the thickness of the suit in the dog's mouth must be between 3 and 5cm. It is forbidden for the decoy to change suit for a trial according to the dog.

Commands

Commands are to be given according to the rules and may be given in the native language of the handler. **Any commands separated by a pause, recall or to make the dog stay will be considered an extra command.**

Score sheets

The sheets must conform to the official model and include all instructions relative to the competition. A sheet is provided for each level. At the time of the trial, 3 sheets will be provided per dog, 1 is an original and 2 are duplicates. The original is given to the Judge, a duplicate is given to the competitor when the results are announced, and the second duplicate is reserved for the organizing club.

Functions and duties of Judges

The Judges assigned to officiate in a trial are designated by the official organization of each participating country. If the Jury is composed of more than one Judge, they will Judge together. The Judges must thoroughly master the rules and conform to them.

The Judges will have total control and are responsible for the deployment of all activity of the competition, and in particular, the ability to regulate the work of the Decoys in their function in all levels. They must apply the penalties described by the well-defined faults, with the strictest observance of the rules. Each penalty corresponds to a fault, to an insufficiency of the dog, or an infraction committed by the handler. All the handlers, even beginners, must know the rules and regulations, and know these penalties.

The decisions of the Judges are final in every case not described in the rules. Only the Judges have the leadership of the trials. All the exercises must be executed under their direction. With the aid of a horn, they will give the signal for the beginning and end of each exercise. The Judges must take care that all exercises proceed in the same manner for all dogs. The trial conditions must be the same for all competitors.

The Judges will total the points obtained by the dog and sign the score sheets. The score sheet will be posted within 15 minutes following the passage of the competitor.

IV – OBEDIENCE EXERCISES

1. Heeling without Leash

6 points

Account of the exercise

See “Instructions Common To All Exercises”.

The handler will follow from memory a pattern (the pattern must be simple) indicated by the Judge or Deputy Judge during the Dog in White, with 3 changes of direction, a right angle or acute angle turn, an about turn, and two stops. Any position may be taken at the stops. These changes and stops will be done at the Judge’s signal. If the handler does not execute the pattern, there is an error on the exercise, which will be penalized in General Attitude.

If the handler makes a mistake that avoids a difficulty, the handler will lose all the points. The handler should not be given anything to hold in their hands during the heeling.

Penalties

Dog forges, lags, or goes wide (whether in a straight line or on an angle, at a halt, or during an about-turn) (per mistake)	-0.5
Dog abandons or does not follow the handler	-6
Handler minor error in the pattern	-G.A.
Handler makes a mistake that avoids a difficulty	-6

2. Absence of Handler

10 points

Account of the exercise

See “Instructions Common To All Exercises”.

The dog will be placed on the ground or on a stable and fixed surface big enough for the dog at a spot indicated by the Judge, in a “down” position for Level I and II. In Level III the position (sit or down) **can (optional)** be determined by a drawing. The Judge may change the position during the competition according to the condition of the field and the weather.

This exercise will last 1 minute, which starts when the handler enters the designated blind. The handler must not look back when he leaves his dog on the way to the blind, nor when entering the blind.

During the Absence of the Handler, a distraction occurs (**sudden noises are allowed**), to which the dog must remain indifferent, without moving or changing position. The diversion will depend on the level. It must never take the form of aggression or provocation. Interference from the Decoy is forbidden. The distance from the distraction to the dog shall be at least 10 m in Level I and II and 5 m away from the dog in Level III.

Penalties

Dog changes position during the 1 min. absence.	-10
Dog changes positions when handler is going to the blind.	-10
Handler looks back towards the dog while he walks to or enters the blind	-10
Dog moves without changing position (penalty per meter)	-1
Dog changes position when the handler returns	-2
Handler shows himself during the exercise	-10
Any irregular or disallowed command	-10

3. Send Away

12 points

Points awarded

In the optimum zone between inside markers	12 points
Between the outside markers and inside markers	8 points
Outside the outside markers	4 points

Description of the exercise

The dog must cross a line (20m long), parallel to the starting line, marked by 2 outside markers placed at each end. At 5 meters inside the outside markers, there will be 2 perpendicular lines 1 meter in length to indicate the optimum zone. The markers can be decorative objects (that are part of the theme.) The distances are 20, 30, and 40 m respectively in Level I, II and III. ***The path should be free from any obstacle or object and in accordance with the orthogonal axes. Avoid using markers that could be regarded as provocation and likely to attract the dog (example: balls/toys).***

Account of the exercise

See "Instructions Common To All Exercises".

The dog will be placed behind the starting line, on a central point marked by a perpendicular line. At the Judge's signal, the handler will give the dog a command to go away. The dog must go straight ahead and cross the finish line.

When the dog has crossed the finish line, the handler will recall the dog back to heel. The dog must return within 20 seconds. ***If there is a command before the dog crosses the finish line, and the dog continues to go forward and crosses the finish line, it will be considered an extra command (-4). If the dog has crossed the finish line and the handler is waits too long to recall the dog, a G.A. deduction will be made.***

Penalties

Commands given by voice and gesture	-2
Any extra commands to send the dog forward. (each)	-4
Dog zig-zags, for each change of direction	-1
Dog returns before command, each time	-2
Dog starts:	
a) before the signal from the Judge	-4
b) after the signal from the Judge	-2
Dog does not pass the line	-12
Extra commands to recall the dog (one only)	-2
Dog does not return within 20 seconds	-12
The dog returns, but wanders 'loosely' back to handler.	-1 G.A.
Handler waits too long to recall the dog	-1 G.A.

4. Positions

Level I 10 points
Level II and III 20 points

Points awarded

	Levels	I	II & III
- for the 3 (3 x 3) or 6 (3 x 6) changes of position		9 points	18 points
- for the command "heel" at the end of the exercise		1 point	2 points

Example A dog in Level III

- Sit, Down, Stand good = 9– 1 m advanced = 8
- Down good, then return to heel = 3
- Point total = 11

Description of the exercise

The exercise will take place with the dog on the ground. The dog and the handler must be able to see each other from a distance of 5, 10 and 15m, depending on the level. It is permitted to call the dog by name before giving the positioning command, but it must be spoken only once along with the command **and without pause**. If not, it is a double command). **The judge must distinguish between moving forward during positions (-1 per meter), and an early return to heel sanctioned by all points remaining in the exercise.**

For each position, the handler is entitled to 2 additional commands. If the dog has not executed the position after the 2 additional commands, the exercise is ended and all points already awarded are kept. Also for the initial position, if the dog changes it, handler must re-command the dog (2 extra commands allowed). The dog that anticipates the position, at one position at least (that which it has just left), may eventually lose another one, if it takes the following position. To avoid a situation where the dog obeys the Deputy Judge's signal, we propose a "triangle" system of signals (the dog faces away from the Judges and each of the three positions are illustrated on a moveable three sided board.

It is stated that as long as the deputy judge or the judge did not indicate the next position, the dog must maintain its position. If he leaves, the handler must re-command. If the next position is indicated and the dog is moving taking the following position (indicated) before command, he loses this position because it is too early.

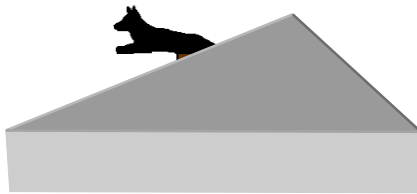

Account of the exercise

See "Instructions Common To All Exercises".

The handler positions himself with his dog sitting at the line of departure. He commands the initial position upon the Judge's signal, and then leaves his dog after a stay command. ***Not respecting the judge's signal (-1GA).***

- The handler must always be able to see his dog during the execution of the exercise.
- At the start, the dog will be placed in a stand, sit or down, at the direction of the Judge.
- In Level I each position is taken once. In Level II and III each position will be taken twice, at the signal given by the Deputy Judge.

Penalties

Levels:	I	II & III
Dog changes from the initial position	-2	-2
Handler does not sit dog first and/or who disrespects judges signal	-1GA	-1GA
Dog does not <i>execute</i> the position <i>indicated</i>	-3	-3
Dog moves towards the handler, each meter	-1	-1
Dog returns to the handler before the end of the exercise; it loses the points for recall, but keeps the points awarded for the changes of positions.(deduction made by the distance advanced from the point of positions)	-1	-2
<i>Dog rotates on itself during positions</i>	-GA	-GA
<i>Dog moves forward ½ meter (exercise is not perfect)</i>	-0.5 -GA	-0.5 -GA
<i>Dog moves forward ½ meter and then returns to its place</i>	-GA	-GA

No diversion is allowed during this exercise.

5. Refusal of Food

Level I 5 points
Level II and III 10 points

Description of the exercise

In Level II and III, six different kinds of food, chosen by the Judge, are placed on the ground. In Level I, nothing is placed on the ground. ***Bones and raw pork cannot be used (risk of infection by the Aujeszky virus).***

It is forbidden to place food closer than 5 m to the small pieces of wood during the Search for Object ***or the Retrieve exercises***. The same applies in the 2 m circle during the Guard of an Object exercise. The Refusal of Food is an exercise, which cannot be executed during another exercise.

Account of the exercise

See "Instructions Common To All Exercises". ***At the beginning of the exercise the dog is placed in a down position. If the dog sits after first piece of food is presented, no penalty.***

- In Level I, only one piece of food is thrown during the obedience exercises, at the place and moment chosen by the Judge. In Level II and III, two pieces are thrown ***or presented*** (at the same time or separately).
- The food must be the same for all dogs.

- The goal is not to set up the dog deliberately, so do not place the food in the work zones, landing area of the jumps, start line of Send away). ***If the food is thrown and falls into the dog's open mouth, and dog spits it out, no penalty. If dog eats or licks the food, exercise is lost (0).***

Penalties

	Level I	Level II & III
Dog licks, eats, or takes food in its mouth (either thrown or on the ground)	-5	-10
Dog moves when food is thrown (per meter)	-1	-1
Handler breaks in or interferes	-5	-10
Dog moves during the throwing of the food: <i>1 point per meter, up to 3 meters; beyond that: 0</i>	-1 pro Meter	-1 pro Meter
Moving upon the handler's return: at the discretion of the Judge	-2	-2

6. Retrieve of a Thrown Object

12 points

Description of the exercise

The time allowed for the Retrieve of the Object is 15 seconds. The object will be chosen by a drawing or chosen by the judge prior to the start of the trial from a list given to the Judge (dumbbell, ninepin, cylinder, plastic bottle, solid bottles if they contain water are ok, small bag, stroller wheel, etc.). The dog must be able to hold it in his mouth, and the maximum weight is 1 kg. All glass or metal objects are forbidden. No other object can be within 5 m because it would turn the exercise into an identification one; also no food nearby. The handler cannot move his feet as long as he/she does not have the object in their hands. The rules say one object yet a pair of shoes tied together is OK as long as it is reasonable. The dog has three changes to hold the object in the mouth before chewing points are deducted.

Account of the exercise

See "Instructions Common To All Exercises".

- On the Judge's signal, the object must be thrown at least 5 m.
- After the Judge's signal, the handler may command the dog to search for the object. Only one retrieve command is allowed.
- The handler will wait for the horn at the end of the exercise before leaving his place.
- A brief command to ask the dog to release the object is allowed – e.g. 'give'.
- ***The handler moves after dog leaves to retrieve, but before dog returns= no penalty.***
- ***Handler moves as dog returns: will be considered as an extra command= -12***

Penalties

Extra or irregular command	-12
Command given by voice and gesture	-2
Object is not retrieved within 15 sec	-12
Dog starts:	
a) before the Judge's signal	-4
b) after the Judge's signal	-2
Dog plays with or chews the object	-1
Dog drops the object while he returns to the handler, each time	-1
Object is returned but the dog is not in sitting position when the handler takes the object.	-1
Dog drops the object at the handler's feet and handler has to pick it up	-2 & -1 G.A. (=total -3)
<i>Handler moves as dog returns</i>	-12
<i>Handler has to move his/her feet to get the object</i>	-12

7. Search for an Object

Level II and III 15 points

Description of the exercise

Time allowed for the exercise: 1 minute.

The object must be a small, unused piece of wood, numbered, 15 cm long and 2 cm in diameter. (for the dogs that have a large mouth). It will be chosen by the handler from several identical pieces, all numbered. At the time of presentation at the Judge's table, the handler takes the wood and ***can hold it in his/her hands for a maximum of 5 seconds.***

Then the handler puts it into **his /her empty** pocket without **any other manipulation or exposure to additional scent and without** showing it to his dog and informs the judge of its number. All the handlers must carry the wood for the same time period. Identical, unnumbered objects are to be placed near that of the wood of the competitor. The object must be placed **with the handler's back to the dog and** without showing it to the dog. **It is forbidden to put one's hand in one's pocket until the handler places the wood with his back to the dog. During this exercise, the object used as thrown object must be out of the reach of the dog.** The wood must be reasonably accessible. No distraction is permitted during this exercise. Like with the retrieve, no other objects should be within 5 m unless part of the theme décor. Unnumbered "distraction" pieces of wood, picked up by another dog, must be exchanged, and "distraction" pieces of wood are put into a plate at the end of exercise to avoid being handled too much.

Account of the exercise

See "Instructions Common To All Exercises".

- Each handler puts his dog in a spot indicated by the Deputy Judge. The handler will then place the object, in view of the dog, 30 meters away in a fictitious square, 1 m x 1 m. The handler will place the little wood with his back to the dog.
- While the handler returns to his dog, other identical pieces of wood (non-numbered) are placed nearby the first one (min. 25 cm) inside the square. There are 3 objects for Level II and 4 for Level III.
- At the Judge's signal the handler sends his dog in search of the object with the command "search and bring". A single command given by voice is allowed. The handler is allowed to let the dog sniff his hands before he gives the command, to make the dog understand the nature of the exercise.
- **The handler moves after the dog has left: no penalty**
- **The handler moves upon return of dog: this is considered as irregular command -15.**
- **The handler cannot move his/her feet as long as he/she has not the object in his/her hands.**
- **Dog that brings 2 woods (1 good, 1 other) will get points earned (deduction for the possible faults committed) minus a GA for the second wood.**
- The handler will give the returned object to the Deputy Judge, for verification by the Judge

Penalties

Handler shows dog the little wood	-15
Commands by voice and gesture	-2
Additional send commands	-15
Object not brought back or not within 1 minute	-15
Dog starts:	
a) before the Judge's signal	-4
b) at the Judge's signal	-2
Dog chews the object	-1
Dog drops the object during the return, each time	-1
Dog drops wood in front of handler and handler has to pick it up	-2 & -1 G.A.(= -3)
Object is retrieved but the dog is not sitting when the handler takes the object.	-1
Dog leaves his place before the return of the handler. (more than radius of 2m)	-15
Dog moves within a radius of 2 m, each m	-1
Dog selects the wrong object	-15
<i>Handler moves as dog returns</i>	-15
<i>Handler has to move his/her feet to get the object</i>	-15
<i>Handler puts his/her hand in his/her pocket before he/she gets to the place where he/she drops the object or he/she shows the object to the dog.</i>	-15
<i>Handler places wood with his/her back NOT to the dog</i>	-15
<i>Handler manipulates the object in a way that is not allowed or gives it an additional scent</i>	-15

V – JUMPING EXERCISES

In Level I the handler must choose 1 of the 3 jumps. He must notify the Judge of his choice at the presentation. In Level II, the hurdle (20 points) is mandatory, and the handler must choose between the palisade (2.1 m = 15 points) and the long jump (3.5 m = 15 points).

See “Instructions Common To All Exercises”.

The following directions are good for the 3 jumping exercises (palisade, long jump, hurdle):

The handler puts his dog into position at a convenient distance from the obstacle.
The handler can count paces during the Dog in White, but not after without losing points.
The handler takes his place immediately in the marked square, to the left or right, near the jump.
The handler cannot touch the jumps or lean on the palisade.
If the dog leaves his place before the start command, so that the handler must reposition the dog, he is penalized one attempt plus points.
The dog is allowed 3 attempts for all the exercises: the palisade, the long jump which counts only the forward jump.
For the hurdle, the dog is allowed to try a total of 3 times forward and 3 times return. If the dog fails or refuses to return, the handler will reposition the dog in the place from where the dog can jump . The handler will then return to his position in front of the hurdle and wait for the signal from the Judge. For the hurdle, a stabilization command is only allowed after the “go” jumps (1st direction). On the return, no stabilization is allowed; the dog has to return to heel.
If the dog fails any jump, no matter which, the handler may not ask to raise or lower the height or length.
The jump command shall be given only by voice. Every gesture or movement of the body will be penalized, but the handler may watch his dog in a natural manner, without staring. All two-word commands must be said without a pause between the words, otherwise it will be considered as an extra command (-5).
If, before stepping into the box area, the handler makes a gesture like throwing a ball, it will be considered as training, loss of all points.
After authorization of the judge for the jump, the handler gives command by voice and makes a short gesture (-2)
A sustained gesture will be considered as a supplementary command (-5).
After each jump, the handler may give one command of his choice to recall the dog to heel or to make it stay behind the jump. If he commands the dog to stay, the handler must go to his dog. If a recall, the dog has 10 sec to come to heel, with or without a command, otherwise there will be a penalty. If the dog is recalled, it can be done with voice or whistle, but it must be the same for all jumps (see the type of distance recall chosen by the handler at the time of presentation).

There will also be a penalty if the dog does not stay behind the jump despite the command. The handler will wait for the sound of the horn announcing the end of exercise, before leaving the jump. If the dog is blocked (given a fixation command) after the jump without taking the position that the handler commanded he will not lose points.

The handler must not show his dog the jump before the exercise.

1. Palisade

max. 15 points

Regulation heights and points						
Height(m)	1.8	1.9	2.0	2.1	2.2	2.3
Level I	15					
Level II	12	13	14	15		
Level III	5	7	9	11	13	15

In Level I, only one height: 1.8 m = 15 points

Description of the exercise

The palisade is made of a fully attached panel at the bottom, up to 1 m in height; then a stack of rough boards 10 cm in height and 27 – 30 mm in thickness, unfinished. The palisade may be 1.5 m – 1.9 m in width. To allow the dog to jump down, it has an incline fixed to the posts at 1.7 m high, and on the ground about 1.2 m from the wall. Slats are placed every 30 cm to break the dog's descent. The incline also supports the palisade. In order to move it easily, the palisade is mounted on beams, in the form of a reverse T. It does not have a reverse jump, so there is no fence behind it.

2. Long Jump

Level III 20 points

Level I & II 15 points

Regulation lengths and points			
Length (m)	3.0	3.5	4.0
Level I	15		
Level II	10	15	
Level III	12	16	20

In Level I, only one length: 3 m = 15 points

Description of the exercise

This exercise does not involve a ditch. It is made up of a frame of 3 planks. The first is 2 m long and 10 cm high, placed in the front, connected with two boards on the sides, each 3 m long and 10 cm high in front, and 20 cm high at the other end and fastened to the ground with a metallic square, to prevent it from swaying.

This frame has coloured elastic bands, **light metal bars, or PVC pipes**, which are fastened to the side boards every 30 cm along the length of the sides.

Without going into the frame, the dog shall jump over a moveable seesaw 'key', 1.95 m long and 1 m wide at the centre, which can move up or down in the frame without touching the sides. Jumps of 3 m to 3.5 m can be obtained. To create a jump of 4 m, simply detach the key from the frame. The key must be constructed so that when the low side touches the ground, the high side is 30 cm from the ground. A dog that steps within the frame is penalized 4 points, plus the loss of an attempt equivalent to a refusal. It must then restart the jump.

3. Hurdle

Level II and III **20 points**
Level I **15 points**

Regulation heights and points			
Height(m)	1.0	1.1	1.2
Level I	15		
Level II	16	20	
Level III	12	16	20

In Level I, only one height: 1 m = 15 points (7.5 + 7.5)

Description of the exercise

The hurdle is made of a moveable panel, 1.5 m wide and 60 cm high, equipped with pivots welded to the supports. The panel is topped with a turnstile of the same width and 30 cm in height. It must fall at the slightest impact and present no danger whatsoever to the dog. It must be adjustable to the required height. There will be no ditch in front of, or behind, the hurdle.

Account of the exercise

- As soon as the dog clears the jump, the handler may give only one command to keep the dog in the specified position upon landing. If the command is given by voice and gesture, there will be a 2 point penalty.
- At the Judge's signal authorizing a return jump, the handler may give only one command for this, though it may be given by voice or gesture. All additional commands for the position or to keep position will be penalized.
- After the return jump, **the dog must return to heel within 10s**. The handler may give one **single** command (**optional**) to call the dog to heel.

Penalties (common to all 3 jumps)

Start before signal (plus loss of 1 attempt)	-4
Start after signal but before command.	-2
Command by voice and gesture	-2
Refusal or going around, forward or return jump	-4
Knocking down the boards, forward or return jump	-2
Missing (attempt failed) forward or back.	-2
Failure to take position behind the obstacle (if command is given)	-2
Any additional command for position, placement, recall	-2
Any additional send command	-5
The dog does not return to heel within 10 s.	-2
Any irregular command results in a penalty to the corresponding points.	

Penalties (hurdle only)

Position command by both voice and gesture, after forward jump	-2
Dog touches the hurdle, forward or return	-1
If the dog pushes the hurdle and it does not fall, each time	-2

VI – BITING EXERCISES

1. Face Attack with Baton

Level I	without obstacle	50 points
Level II	with obstacle	40 points
Level III	with obstacle	50 points

Breakdown of points

Start	10 points
Attack	30 points in Level I & III (20 in Level II)
End and Recall	10 points

Description of the exercise

Duration:	10 seconds
Distance:	30 m (Level I) 40 m (Level II) 50 m (Level III)

Allowed: Barrage, threats, intimidation, charging at the dog (2 steps maximum), avoiding during the attack if the dog loses its bite. An accessory may be used in place of the baton during the attack with obstacle. *In Level I, only the stick is allowed.* In Level I, the arms must be accessible for the dog to bite.

Forbidden:

Avoiding at the entry, striking the dog, any gesture or behaviour of the Decoy which may cause pain to the dog – if this happens, the Decoy is removed from the field immediately and may be reported.

Obstacles:

- Moat or plastic water tub, maximum water depth 20 cm.
- Hay bales
- Tires, piled up or placed upright
- Bands fastened vertically to a crossbar
- Netting

Obstacles must not be more than 80 cm wide, except for water obstacles, or flat obstacles that have a maximum of 25 cm in height. The tires, hay bales, and the netting must not exceed 80 cm in height. The length of the obstacles will be 8 to 10 m and must permit the Judges to evaluate the attitude of the dog as it approaches the attack. No obstacle must injure the dog or do it any harm. In the spirit of this exercise, the obstacle is meant to slow the dog down in order to judge his courage in the face of an accessory or baton, and it should never present any danger. The Decoy places himself 5 m behind the obstacle at the midpoint of its length.

Cross beams (poles) can be placed above the obstacle the Decoy has to show himself in front of the obstacle and then remain visible at all times to the dog.

Account of the exercise

See "Instructions Common To All Exercises".

- So that there will never be any confusion regarding the spirit of the dog, we ask it to attack the Decoy. The decoy must signal his presence. The decoy must present himself/herself clearly for the first 10 m that the dog runs in order to draw the dog's attention to the decoy. **For the Face Attacks, the decoy must attract the dog with the stick.** If need be, the Judge will send the Decoy out 10 to 20 m, then authorize the dog to be sent out as soon as the Decoy is behind the obstacle. To take his place, the Decoy must clear the obstacle each time, whenever possible.
- The Decoy should place himself at least 5 m behind the obstacle. He must not charge the dog while it is in the air. If he wants to charge the dog, he must adjust the distance to maintain the 5 m distance from the obstacle.
- For each attack, the decoy must absorb the dog while maintaining the line of attack. Avoiding is not allowed on entry. If the absorbing movement is too anticipated, it becomes an involuntary avoidance by the decoy. If this happens, one should not count the delayed time to bite.
- The Decoy will not stop moving until the command to end the exercise, then he must immediately become absolutely still.
- **For all attacks, once the decoy has started to work at the signal of the judge, and the handler gives another stabilization command (voice or gesture), it will be considered as avoiding early departure and penalized -10 for the start, -5 for GA; and the dog has to start again.**
- **For all attacks, a dog not biting at time of recall, or returns before the judge's signal, loses 10pts for the return (plus points associated with seconds not biting).**
- **For all attacks, a dog that is not biting at the end of the exercise, but is trying to regain the bite, and whose handler recalls the dog on the judge's signal will lose 5 points for the return (plus points associated with seconds not biting).**
- **Dogs that stop biting at the judge's horn and returns to handler will lose 5 points for the return.**
- **For all attacks, a dog that creeps forward at the start line will lose -1 per meter up to 10 meters: it is considered an early departure before authorization of the judge and thus penalized.**

Penalties

Levels:	I	II	III
Starting before the Judge's signal (plus -5 for G.A.)	-10	-10	-10
Second offense of start before Judge's signal	-50	-40	-50
Starting after the Judge's signal before command.	-5	-5	-5
Additional commands to attack (only 1 allowed) : <i>if dog leaves at first command, no additional commands are allowed</i>	-10	-10	-10
Any irregular behaviour before or during the exercise	-50	-40	-50
Per second not biting	-3	-2	-3
Per rapid change in bite	-1	-1	-1
Per second biting after out command (1 second allowance)	-2	-2	-2
Additional bite after end of exercise	-2	-2	-2
Additional recall command (only one is allowed)	-5	-5	-5
Not biting at the time of recall (plus per second not biting)	-5	-5	-5
Failure to return within 30 seconds	-10	-10	-10
Any irregular behaviour after end of exercise	-10	-10	-10
Dog does not attack or does not bite (the dog cannot execute a Stopped Attack or will lose the points gained in that attack if already executed)	-50	-40	-50
Handler leaves starting line during the exercise (a lateral movement behind the line is allowed if needed to see his dog, but he must remain motionless after the out command)	-50	-40	-50
Handler uses the course for training.	-50	-40	-50
Dog hesitates in front of the obstacle <i>(Deduction from start points).</i>		-5	-5
Dog bypasses the obstacle (not penalized on return) <i>(Deduction from "bite" points)</i>		-10	-15
<i>Dog creeps forward at the start line -1 per meter</i>	-1	-1	-1
<i>Dog stops biting at the judge's horn and returns to handler</i>	-5	-5	-5

2. Face Attack with Accessories

Level III 50 points

Level II 40 points

Description of the exercise

Distance: 30 meters

All the regulations for this attack are identical to those of the "Face Attack with Baton".

Allowed accessories (these are only meant to impress or upset the dog)

- branch, rattle, cloth, newspaper
- piece of plastic or sack, plastic water bucket (empty or full)
- any noisy (but harmless) object, etc. ***The accessory must not be too big and must be easy to cross without the dog getting hurt. It has to be in the same condition at the beginning and the end of the competition. The decoy cannot have any kind of hand protection. (e.g.: gloves, gutters, scabbards) If the accessory has a grip, it cannot be larger than a hand.***

The accessory used for this attack must not completely cover the dog during the bite.

If the dog aggresses a 'civilian', the exercise will be terminated immediately, and all points lost. If a dog is considered to be dangerous, the team will be removed from the field immediately. If the decoy believes that the dog will hit him in the face, he can protect himself by pushing off or avoiding the dog.

Account of the exercise

(Identical to that of the "Face Attack with Baton")

For the Attack, the Decoy must use the accessory to test the dog's courage but must not use it to entice the dog to miss.

Penalties

(Identical to that of the "Face Attack with Baton")

3. Flee Attack

Level II and III	30 points
Level I	50 points

Breakdown of points

Level	I	II & III
Start	10 points	10 points
Attack	30 points	10 points
End and recall	10 points	10 points

Description of the exercise

Distance: 30 - 40 m
Duration: 10 seconds

Account of the exercise

See "Instructions Common To All Exercises".

- ***For reasons of fairness, it is mandatory that the two Flee Attacks be done in the same way, by the same decoy. The decoy must have the same attitude for all Flee Attacks.***
- The decoy will start at 10 m from the ***departure line***. The Judge will sound the horn to start the exercise, so no time is lost.
- Ideally, engagement is between 30-40 meters.
- Decoy must accelerate when dog is within 10 m and keep this pace until impact.
- The Decoy will escape without looking back or trying to avoid. He will be armed with a revolver and will fire two shots while the dog is biting.
- He will defend himself vigorously, but not brutally, to test the dog's bite.
- When the handler gives the end of exercise command, the Decoy will immediately remain totally motionless.

Penalties

(Identical those of the "Face Attack with Baton")

- ***Level 2&3 dogs will lose 1 point per second not biting.***
- ***Level 1 dog will lose 3 points per second not biting.***

4. Stopped Flee Attack

Level III

30 points

Breakdown of points

Start	10 points
Attack	20 points

The stopped attack will be judged on one-third of the biting points earned in the other face attacks (base total: 30 + 30 = 60 + starting points, see examples).

Description of the exercise

Distance: 30 - 40 m

Each handler will draw by lots, for his own dog, the order of the 2 flee attacks. The order will be known only by the Judge. ***The judge must indicate on the scoresheet the order of the Stopped Attack before the competitor begins the exercise. If two judges are officiating, they must be informed of the draw.*** The Decoy will not know if it is a stopped attack. If the dog does not bite on any of the other attacks, the Stopped Attack will not be executed. If the Stopped Attack has already been executed, the points earned will be revoked.

Account of the exercise

See "Instructions Common To All Exercises".

- If the exercise is a Stopped Attack, at the Judge's signal, the official in charge of the food, raises a red flag after the dog has started. In a biting attack the official raises a green flag.
- The Deputy Judge immediately touches the handler's shoulder who commands his dog not to bite.
- The Decoy will continue to escape after the recall command; neither changing his pace, nor provoking the dog, nor firing the revolver.

Penalties

Start (see the start penalties in the other attacks)	
Dog bites	-30
Recall at 3 m (no deduction)	no penalty
Per additional meter	-2
Additional recall command (only one allowed) -if the dog returns within 5 meters of the handler. -if the dog returns outside of a 5 meter radius (additional recall prohibited, he retains 10 points from the start)	-5 -20

1ST example: points earned 28 + 26 = 54 / 3 =18
 points assigned at start +10
 maximum points =28
 distance at recall: 5 m -4
 points for Stopped Attack =24

2nd example: points earned 30 + 30 = 60 / 3 =20
 dog started after signal 10-5 +5
 maximum points =25
 distance at recall: 2 m -0
 points for Stopped Attack =25

3rd example: points earned 30 + 30 = 60 / 3 =20
 points assigned at start +10
 maximum points =30
 distance at recall: 4 m -2
 returned more than 5 m away -20
 points for Stopped Attack =10

5. Search and Escort

Levels II and III

40 points

Breakdown of points

Discovery 10 points
 Escort 30 points

Description of the exercise

Number of hiding places: 6 fixed plus one movable, which may be placed at the discretion of the Judge. ***During this exercise, the second decoy needs to be at least 5 meters from the field in an area that can be closed so that if the dog leaves the field they cannot see and reach the second decoy.***

Time allotted for search and bark: 2 to 3 minutes at the Judge's discretion, depending on the surface of the field. It is important that the Judge or a member of the Jury is placed where he can see what happens in the blind. In effect, if the dog is not vigilant, the Judge can authorize the Decoy to flee, and the meters escaped would be penalized.

The Decoy absolutely must follow the course indicated by the Judge, to put all the dogs on an equal basis. His walk must be natural and his attitude as identical as possible toward all the dogs, without provocation on his part. He must attempt to escape three times, at his own initiative, according to the behaviour and vigilance of the dog, independently of the possible escape from the blind. In case the dog loses vigilance after the third escape, the judge may penalize the dog and request an additional escape **before the horn to signal the phase of the guard of the decoy**. The decoy should not fixate too much on an obstacle to steal meters. He can go over a particular obstacle no more than three times before escaping. **During the second pass over of the obstacle the judge may inform the decoy that he still has another chance to pass over. The decoy cannot use the same obstacle more than once.**

This exercise must demonstrate the dog's ability to bring a fleeing lawbreaker to bay, and the Decoy must act in this situation like a prisoner attempting to escape.

When the Dog in White appears, the Judge impresses upon the Decoy the proper attitudes and behaviour, he defines the course and maintains a good balance between the spirit and execution of the exercise.

The use of jumps in order to assist in fleeing is forbidden.

Obstacles may be used as a diversion during escapes, but not in more than 2 escapes.

Stay commands at the end of escapes are forbidden. The end of exercise command consists of the dog's name, followed by the handler's choice of a command word. **(There cannot be a pause between the two words).**

Account of the exercise

See "Instructions Common To All Exercises".

- The dog and his handler will leave the field accompanied by the Deputy Judge. They return at the signal of the Judge, when the Decoy has hidden. If the dog is vigilant, after the discovery of the Decoy, the handler himself will (upon the Judge's approval) call the Decoy out of the blind. He must walk without changing his pace. Once the dog has alerted, the handler, on authorization of the judge, will approach at 3 m to the hiding place **at a point marked on the ground at 3 meters of the blind** before asking the decoy to step out. If the handler runs to the blind there will be a penalty against General Attitude. Also, if the dog leaves the "zone of vigilance", the Judge may allow the Decoy to attempt an escape. A dog is considered vigilant if he looks at....follows....watches.... the decoy. If the judge is alone, he/she should place themselves close to the discovery spot so they can have a good view. If the dog does not make the discovery in the allotted time, then the exercise is cancelled. If the dog makes the discovery but does not bark in the allotted time, he loses the discovery points; but the handler, on the Judge's signal, will return to the blind to continue the exercise. As long as the dog has not signalled the discovery of the Decoy by barking, the Judge may not allow the Decoy to leave the blind even if the dog has passed and continues his search. It will be allowed the regulation time for the search. If the dog returns to the handler, within a radius of 3 m, before the end of the allotted time, the handler may give an additional search command, which will be penalized.

If the dog bites the Decoy, whether it has barked or not, it loses 5 points. If the dog alerts the handler by barking, without having discovered (see) the Decoy, it is penalized 5 points.

Decoy needs to be hidden to keep the spirit of the exercise. If the dog leaves the field (if the fence is not substantial), the handler **must** call back his/her dog **He will not be penalized, and the clock will stop. At the judge's signal, the handler stays at his/her place and calls back his/her dog. The exercise continues when the dog is back in the field. If the dog returns within 3 meters of the handler, another Search command is allowed and will not be penalized. However, if the field is regarded as well fenced and the dog leaves, the clock will not stop. The judge will signal the handler who stays at his/her place to call back his/her dog. The time allotted for the exercise will not be changed.**

- **If dog restarts search without assistance from the handler, no penalty.**
- **If extra command is given (-10).**
- **Once decoy is discovered, a dog that bites decoy for 15 seconds without barking will lose 10 points, plus -5 GA. The judge will signal the handler to go to the 3m mark. Additional "out" commands will be penalized.**

1. If dog does not stop biting after 30 seconds, the team is disqualified.

2. If dog stops biting, the handler will ask decoy to step out of the hiding place.

- During the course of the exercise, the Decoy must avoid when he attempts to escape, and keep as far as possible from the dog. There will not be a one-meter allowance for the escapes. He will stop his escape attempts only when the Judge sounds the horn and the handler gives the command, about 3 seconds after the bite. The distance escaped, while the dog is biting, will not be penalized; but if the dog lets go before the handler's command, the Decoy will continue to escape. The Decoy may not resume walking after an "out" command, except on the Judge's signal. During the entire escort, the handler must remain at least 3 m from the Decoy, behind or beside him, but never in front of him. **If meters lost are more than 30, the team keeps the discovery points minus the penalties for faults during discovery.**
- The Judge indicates the end of exercise by several horn blasts. The handler commands "stop" and the Decoy stops walking. When the escort stops, the dog assumes a guard in place, with the same penalties of those for Defence of the Handler. The handler recalls the dog to heel and puts himself at the disposal of the commissioner.

Penalties relating to Search and Escort

Additional search command (only one allowed)	-10
Dog does not search despite the second command	-40
Dog does not discover the Decoy during the allotted time	-40
Dog does not bark during the allotted time	-10
Dog bites within the blind	-5
Dog does not guard closely at the blind, per m escaped	-1
Handler runs to the blind (deducted from G.A.)	-2
For each bite during escort or after "out"	-2
Additional command to "out"	-2
Dog lets the Decoy escape, per meter	-1
Handler does not maintain 3 m distance during escort	-10
Handler interferes with Decoy during escape	-30
Dog does not guard closely for 5 seconds	-5
Dog barks without having discovered the Decoy	-5

6. Defence of the Handler

30 points

Description of the exercise

Duration of the exercise: 10 seconds

The exercise is based upon 5 principals:

1. There will always be a preliminary meeting (a handshake) between the Decoy and handler, with or without conversation. The handler may respond to the Decoy's greeting with a very ordinary tone of voice. ***The judge may prohibit the handler from responding to the decoy after initial greeting, i.e. not say anything during the exercise.***
2. The difficulty created for the dog will be increased progressively, according to the level.
3. At each level, the Decoy's aggression will be clear and evident, and made with both hands.
4. At the moment of aggression, the Decoy and handler will remain motionless for 2 sec. If the dog bites within 2 sec, they will resume normal work; if the dog does not bite during the 2 sec, the Judge will stop the exercise.
5. The dog must only react if his master is the aggressed upon.
6. The handshake must be made by the Decoy, who is the aggressor.
7. The scenario for Defence of the Handler, as well as off leash heel, will be explained to all competitors only once, at the passage of the Dog in White. Modifications and additional explanations may be given after the Dog in White, at the request of a handler's representative.
8. The use of accessories must not become a provocation to the dog or handler, only to protect himself or forestall the protection of the handler.
9. Decoy must not try to lure away the dog intentionally but must follow the predetermined route during the Dog in White. The judge will decide if the dog can be lured away by the decoy up to a distance of 10 meters. Handler needs to keep the dog beside them, to the left or right but not between their legs unless they are not moving. There will always be a handshake but not always a dialogue. Both decoys can shake the handler's hand. Judge can insist that handler not speak after the initial command.

The handler can respond normally at the initial greeting if not told to do otherwise, **otherwise he/she will not say a word**. Decoy will not provoke before the handshake. After the handshake, in a scenario with two decoys, the decoy who will not hit must never find themselves less than 3m from the handler during diversions that look like provocation. A dog that does not 'out' will lose at most 10 points (one second delay for out is allowed); 20 points are kept for the bite portion; all the rest of the points are cumulative. If the dog does not react within 2 seconds of the hit, all points will be lost. It is important to note the difference between not reacting and a delay to reach the bite. A delay to bite because of an obstacle or odd placement is allowed.

The Decoy must strike the handler and hold the strike for 2 s. during which time the dog must bite. During the Defense of Handler, the handler must stay at least 3 m from the Decoy, until after the "out" command and return of the dog to heel.

A distinction is made after the handshake (with the aggressing decoy) between a cheap shot quick bite and a full bite. The penalty will be -2 instead of -2/m up to the place of the aggression. For any bite on the wrong decoy the exercise is lost.

Account of the exercise

See "Instructions Common To All Exercises".

Progress of the exercise, starting with some examples of possible situations:

- Simple conversation, after the Decoy and handler meet, ending in aggression
- After the conversation, the Decoy walks away and without wavering, returns to hit the handler.
- The same, but he tries to trick the dog's vigilance through deception
- The Decoy shows aggression toward a third person, to try to provoke an untimely reaction from the dog
- The third party pretends to start a fight with the handler himself
- The Decoy acts aggressively toward the handler in a situation similar to daily life, etc.
- The Judge will give a horn blast authorizing the "out" command. The dog must then guard the Decoy closely for 5 sec, after which the Judge will indicate the end of exercise, and the handler will recall the dog.
- ***The dog that is guarding during 5 seconds, but comes back after the signal of the horn, i.e. after authorization of the judge, but before the command of the handler (-2)***

Penalties

Handler talks to the dog after command at the start of exercise	-30
Handler responds to conversation without preliminary authorization to do so	-30
Dog bites before or during the meeting or conversation	-30
Dog bites after the meeting but before the aggression, penalized per meter from the spot intended for aggression	-2
Dog moves away from the handler without biting, at any time (with one-meter allowance) penalty per meter	-1
Dog abandons the handler, more than 10 meters	-30
Dog attacks the third person	-30
Dog does not defend during the 2 sec aggression	-30
Handler encourages his dog, does not stay 3 m away during the Defense, or when the "out" command is given	-30
Bites after the "out", per bite	-2
Per second not biting	-2
Dog does not return within 10 seconds of the recall command	-5
Dog does not guard closely for 5 seconds	-5

7. Guarding an Object

Level III

30 points

Description of the exercise

The object will be placed 3 meters from the 5 meters circle (preparation zone), in the same place for all competitors. The handler takes the object and places it on the 5 meters circle line, upon the judge's signal (horn), the handler will then place the object as requested by the judge in the centre of the inner/smaller circle. The handler tells the dog to guard the object and goes to the designated blind without looking back at the dog.

An object will be placed at the centre of a 2 m radius circle. A second concentric circle of 5 m will be traced. The Judge may use one or two Decoys, but the second Decoy must stay at least 10 m away while the other Decoy works. Whatever the case, 3 attempts to steal the object are mandatory; the penalties are cumulative and identical for the 3 attempts, according to the faults committed. If the Decoy succeeds in stealing the object, on any attempt, the dog loses the 30 points of the exercise.

During any one of the 3 attempts, which are the same for all competitors, the Decoy must use certain accessories designed to divert the dog's attention. They must never serve as a shield to prevent the dog from biting. An impassable accessory is forbidden; it must permit the dog to pass through. The accessory does not have to be identical to the other accessories used in the competition. The accessory must not be dropped intentionally within the 5 m circle. In the case where the dog confuses the accessory with an object to be guarded, a third passage will be used.

Objects to guard, which could be dangerous to the dog, are forbidden.

The distance at which the dog bites, without accessory, *is* the distance between the **object** and the closest part of the decoy's body. With the accessory, the part of the accessory closest to the **object** counts.

When the decoy enters **a** circle (**distance to the object <2m or <5m**) with any part of his body he must continue to enter and approach; if decoy is within the inner/smaller circle he will have 30 seconds to make an attempt. Between 2 – 5 meters, if the dog comes out to bite, the decoy can avoid or block the dog with the accessory. Nonetheless, the accessory cannot help him to avoid the dog. If a part of the accessory is within 2 m of the object, it will be as if the decoy is within 2 meters and he can try to steal the object. There can only be one object to guard on the ground.

The Decoy must steal the object; he must have a neutral attitude until 2 m from the dog, unless the dog takes the offensive (a legitimate defence).

Definition of biting: same as that of Stopped Attack or Discovery in the blind.

The circles traced on the ground serve only as a reference point in order to evaluate the distance the object is carried away from the initial position of the object. It is therefore necessary mentally to recreate these distances as a function of the position of the object. Example – The dog made its last bite at 4 m then let itself be dragged 6 m, the penalty is doubled.

- | | | |
|----------------------------------|----|--------------------------------|
| 1. Dog bites at 4m | -5 | |
| 2. Lets itself be dragged for 2m | -2 | making -7 points total. |

At the end of the exercise, and at the appearance of the handler, the dog goes to him = penalty to G.A.; but if the dog moves away from the object before the horn blast allowing the return to the handler, loss of 1 point per m up to 10 meters and beyond = 0.

Account of the exercise

See "Instructions Common To All Exercises".

- The handler places the object at the centre of the 2 m circle and commands the dog to guard it before going into the blind.
- The Decoy enters the 5 m circle in a neutral manner, without being aggressive or trying to attract the dog's attention. If the dog lets him enter the 2 m circle, the Decoy must then use all possible ruses, threats, intimidations, avoidances, which he thinks may impress and trick the dog into dropping his guard. He will have about 30 seconds to steal the object.
- If the dog bites before the Decoy is able to touch or take the object, the Decoy must wait 2 seconds before moving away in a normal manner or dragging the dog if he has maintained his bite. If the dog bites after the Decoy has stolen the object, the Decoy must put the object down at his feet as soon as possible, and proceed as above.
- If the dog takes the object in its mouth, or puts at least one paw on or within the object, without biting the Decoy, as it is in contact with the object, the Decoy must pull the object outside the 2 m circle (**at a distance of 2 meters**) before the Judge can stop the exercise, considering the object ineffectively defended.

- To determine the place where the dog bites, the Judge will take into account the position of the Decoy. To determine the distance to which the dog has let itself be dragged, the Judge will take into account the position of the dog, the four paws outside of one of the circles.
- The Judge will always have the right to apply a penalty against G.A. if the guarding of the object, even if effective, may not be considered as perfect.
- The handler cannot look back at the dog while heading for or entering the blind or they will lose all points of the exercise.
- A dog that bites the object will lose general allure points, and if the dog destroys the object they will lose all points.

Penalties

Dog bites the Decoy within the 2 m zone before he has touched the object	no penalty
Dog bites the Decoy within the 2 m zone and lets itself be dragged to, but not beyond, the circle	no penalty
Dog bites the Decoy within the 2 m zone and lets itself be dragged beyond the circle, per meter	-1
Dog bites and lets itself be dragged beyond 5 m distance from the place where it bites	-15
Dog lets itself be dragged beyond 5 m , does not let go within 10 sec	-30
Dog lets the Decoy take and move the object, then bites, regardless of the distance, inside the circles, by meter	-1
Dog lets the Decoy take and move the object, then bites, at 5 – 10 m	-15
Dog lets the Decoy take and move the object beyond 10 m	-30
Dog bites the Decoy between 2 and 5 m	-5
Dog bites the Decoy beyond 5 m (exercise is ended)	-30

VII – TABLE OF POINTS

To take into account a necessary progression and to increase the difficulties gradually, it is logical to view the organization of trials in 3 Levels, giving to each a maximum of points:

200 Points in Level I
300 Points in Level II
400 Points in Level III

The table below presents a convenient notation for the proposed totals.

Exercises	Levels:	I	II	III
Heel (without leash)		6	6	6
Absence of the handler		10	10	10
Refusal of food		5	10	10
Sending out ahead		12	12	12
Retrieve of thrown object		12	12	12
Positions		10	20	20
Search for object		-	15	15
Palisade		15*	15*	15
Hurdle		15*	20	20
Long Jump		15*	15*	20
Face attack with baton (+ obstacles in II and III)		50	40	50
Flee attack		50	30	30
Defence of handler		30	30	30
Stopped flee attack		-	-	30
Search and escort		-	40	40
Face attack with accessories		-	40	50
Guard an object		-	-	30
TOTAL		200	300	400

* Optional exercises

QUALIFIERS

0 – 299	Insufficient
300 – 319	Sufficient
320 – 339	Good
340 – 359	Very Good
360 – 400	Excellent

In case of tie scores, the dogs will be judged according to the following criteria:

1. Most points in biting exercises,
2. Most points in obedience exercises,
3. Most points in jumping exercises.

VIII – THE JUMPS – TECHNICAL PLAN

1. Hurdle

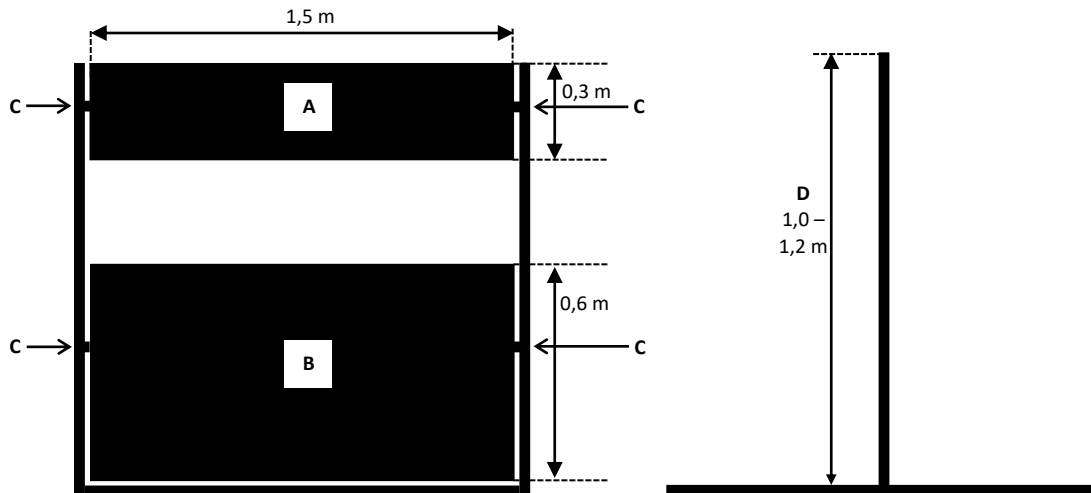

A	Turnstile, movable 1,5 m x 0,3 m
B	Panel, movable 1,5 m x 0,6 m
C	Pivots
D	Adjustable height 1,0 – 1,2 m

2. Palissade

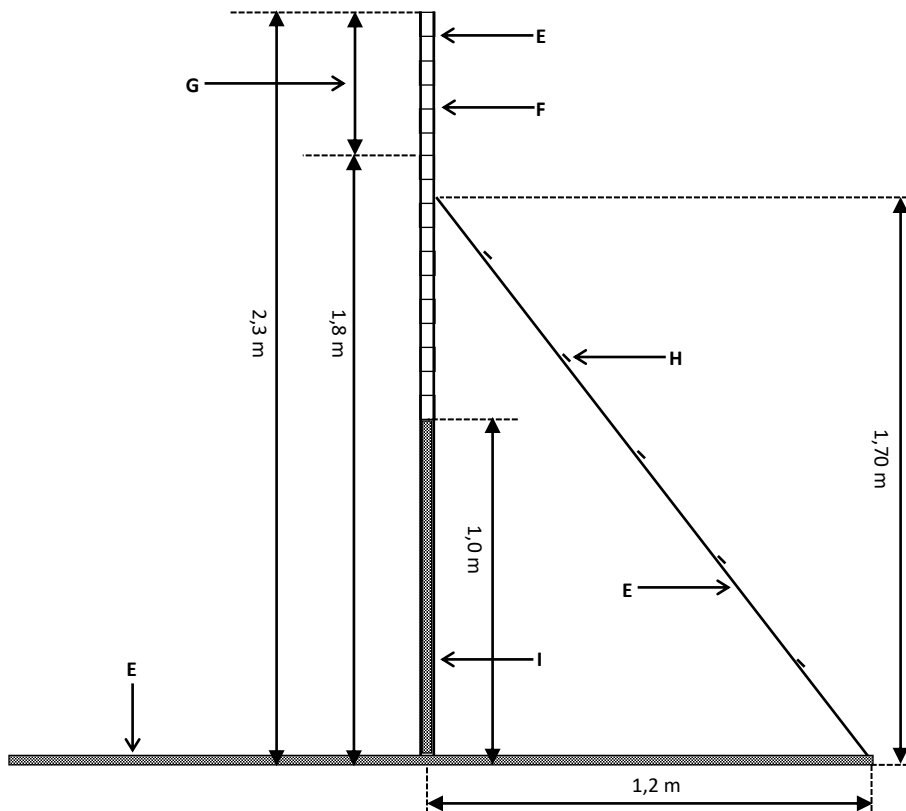

The width of the palissade 1,5m. -1,9 m.

E	Timber
F	Planking of 10 cm and 27-30 mm thick, not planed
G	Adjustable height between 1,8m-2,3 m
H	Arranged slats with 30 cm distance
I	Fixed panel 1 m

3. Long jump

The frame from the side

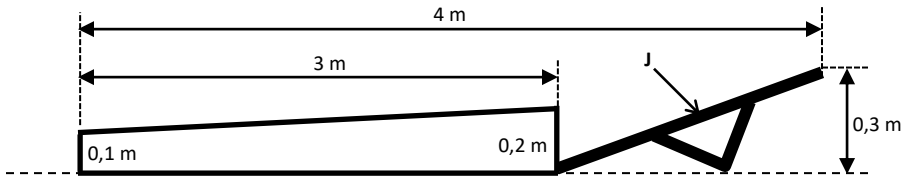

The frame from above

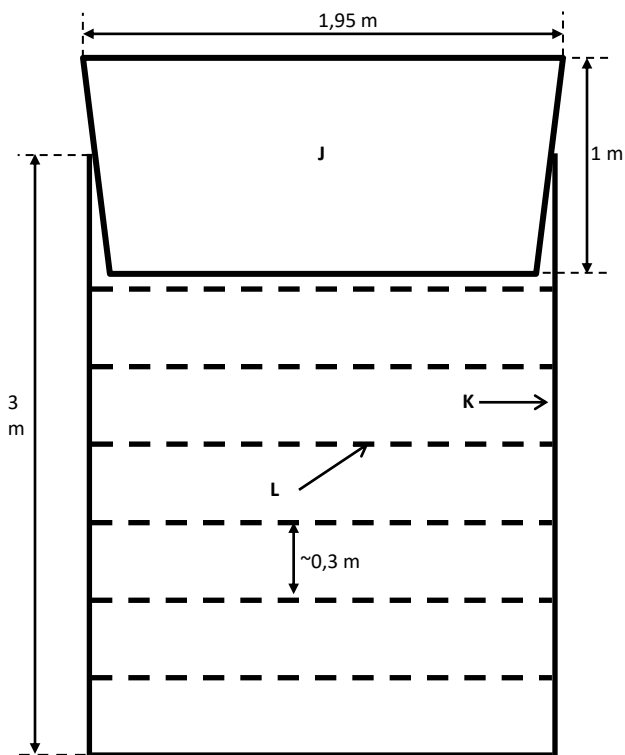

The front side of the frame

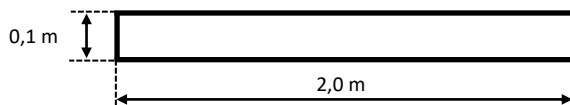

J	Movable seesaw "key"
K	Wooden or metallic frame
L	Coloured elastic bands or light metallic bars or PVC bars, wide appr. 30 cm distance

IX – ABBREVIATIONS

G.A.	General Attitude
Ech.	Level
H.A.	Decoy
Handler	dog handler, master, conductor
Kg	kilogram
m	meter
mn	minute
Sec	second
P	point
Suppl.	additional

X – FINAL PROVISIONS

1995 Provisions

The current International Rules for MONDIORING Competition (RCI-MR) were discussed and adopted by the Commission for Working Dogs in a meeting on March 17, 2001 at Nova Gorica, Slovenia.

Only the competent national association is allowed to permit tests in their country. In case of dispute in the interpretation, the French text is applied.

The FCI Utility Dogs Commission
President: Eberhard Strasser
March 17, 2001, Nova Gorica, Slovenia

This RCI-MR (*International Mondioring Rules*) has been adopted by the General Committee of the FCI in May 2002 (Weissbad).

The changes in bold and italics were approved by the FCI General Committee in Paris, October 2016.

The changes in § VIII – THE JUMPS – TECHNICAL PLAN were approved by the FCI General Committee by email, November 2019.